

# DESCRIPTION

AMC MODEL SWN-10M1-TRA-PE7132 IS A FORM, FIT AND FUNCTIONAL TRANSFER SWITCH DESIGNED TO OPERATE BETWEEN THE 10 MHz TO 1 GHz FREQUENCY RANGE WITH LOW INSERTION LOSS AND HIGH ISOLATION PER SCD# PE7132.

REVISIONS				
ZONE	REV.	DESCRIPTION	DATE	APPROVED
-	-	ORIGINAL RELEASE JOB# 411288	3/1/05	

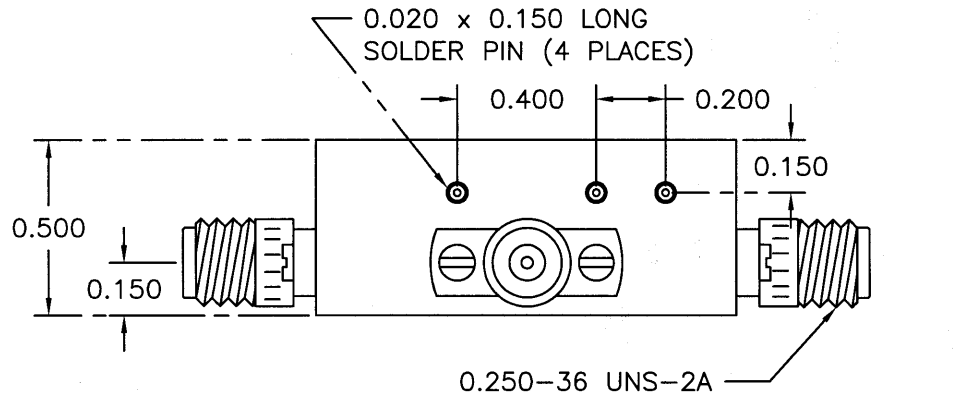

# MECHANICAL OUTLINE

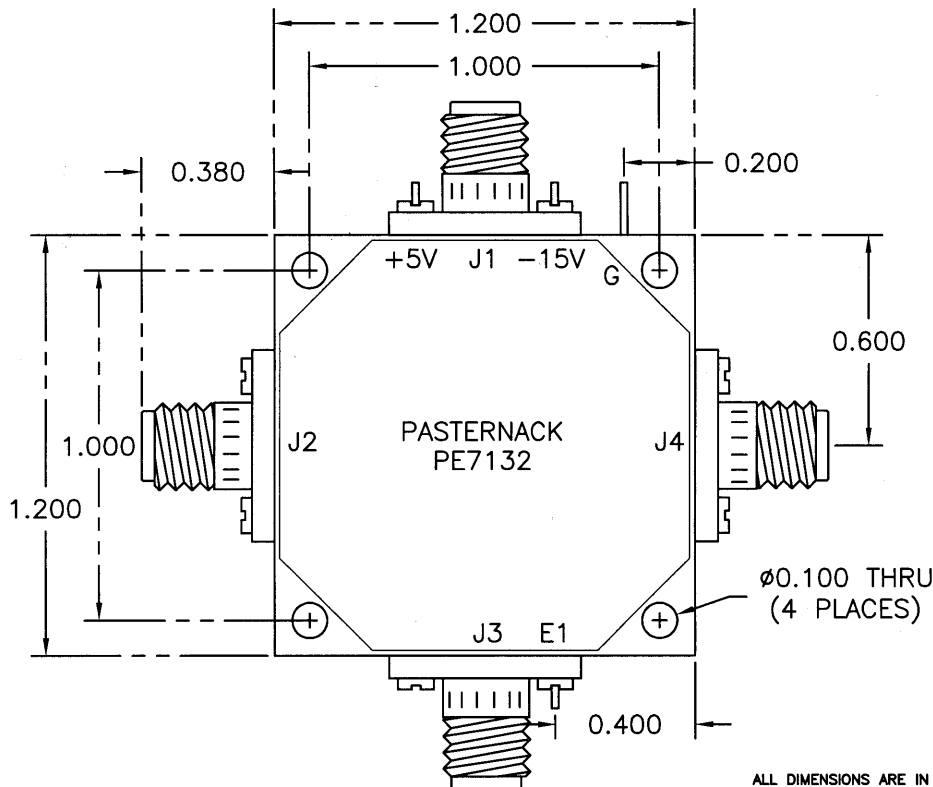

ALL DIMENSIONS ARE IN INCHES  
 TOLERANCES:  
 X.XX ±0.020  
 X.XXX ±0.010

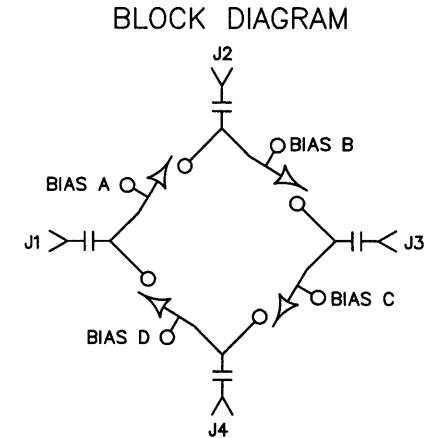

# AMERICAN MICROWAVE CORPORATION

7311-G GROVE ROAD  
 FREDERICK, MARYLAND 21704 USA  
 TEL: 301-662-4700 FAX: 301-662-4938  
 WEBSITE: [www.americanmicrowavecorp.com](http://www.americanmicrowavecorp.com)  
 E-MAIL: [sales@americanmicrowavecorp.com](mailto:sales@americanmicrowavecorp.com)  
 ISO 9001:2000 CERTIFIED



APPROVALS		DATE	TITLE		
DRAWN <i>g2g</i>		3/1/05	MECHANICAL OUTLINE		
CHECKED			SWN-10M1-TRA-PE7132		
ISSUED			10 MHz - 1 GHz TRANSFER SWITCH		
SIZE	FSCM NO.	DWG NO.	REV.		
A	60483	100-7367	-		
SCALE N:S		SHEET		2 OF 3	

